

PCI Membranes
UF, NF & RO Modules



B1 Series

The tubular B1 module provides the user with a robust, proven, ultra filtration, nanofiltration and reverse osmosis module and a wide range of fully interchangeable membrane elements.

Each module, up to 3.6m long, comprises 18 perforated stainless steel tubes in the form of a shell and tube, each tube fitted with a membrane element. The shell, or shroud, is also fabricated from stainless steel and has outlets fitted for the permeate, the liquid that passes through the membrane.

Flow of the process fluid through the tubes is effected by specially designed end-caps whose design varies depending on the process requirements – Series Flow, Twin Entry Flow, Parallel Flow.

To ensure system integrity, permeate sampling from individual modules is available. Manufactured with materials approved by the FDA, CFR21 and EU regulations.

Series Flow Arrangement

For reverse osmosis systems the “series flow” module has channels moulded in the end-caps connecting all the 18 tubes in series.

REPLACEABLE MEMBRANE CORE

Allows fast, cost-effective remembraning, reducing downtime.

PROVEN MEMBRANES

With applications in food, beverage, chemical and pharmaceutical industries.

COMPACT MODULE DESIGN

Quick and easy plant construction.

TUBULAR MODULE

Minimal prefiltration required, suited to liquids and high levels of suspended solids.

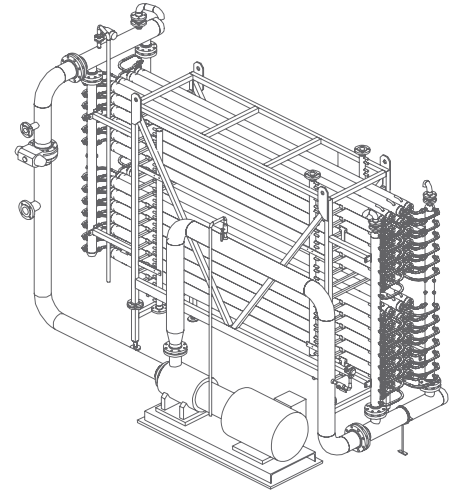

Dimensions			
Length (m)	1.22	2.44	3.66
Membrane Area (m ²)	0.88	1.75	2.63

Connection	
Permeate	End Cap dependent
Feed	End Cap dependent

Additional Details	
Operating Pressure	Up to 64 bar (End Cap dependent)
Operating Temperature	Up to 80°C
Shroud Material	AISI 316 Stainless Steel
Membrane Type	Suitable for UF, NF & RO Membranes

Twin Entry Flow Arrangement

An end-cap type (known as “twin” or “double-entry”) that provides two parallel channels each of nine tubes in series. Allowing viscous materials to be processed and higher crossflow velocities to be used with overall pressure drop minimised.

CASE STUDY HISTORY

- Multi-stage Treatment of Landfill Leachate
- Tomato Juice Concentration
- Tubular membrane effluent treatment plant

Parallel Flow Arrangement

This end-cap allows all 18 tubes to operate in parallel allowing the highest crossflow velocities to be used with acceptable pressure drop.



PCI Membranes

UF, NF & RO Modules - Series Flow (RO) Arrangement

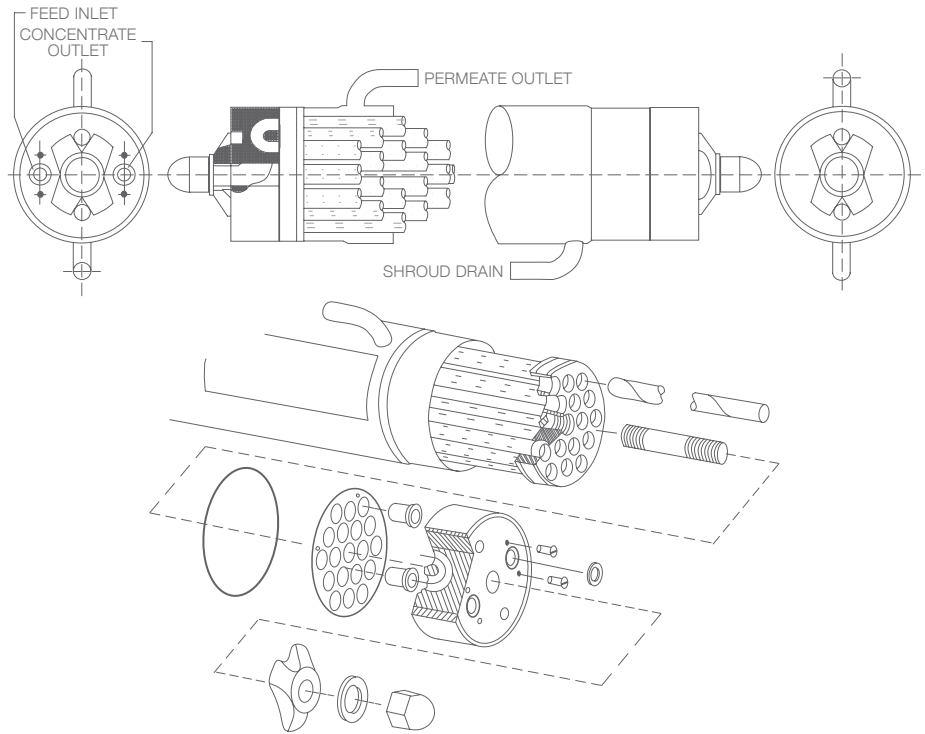
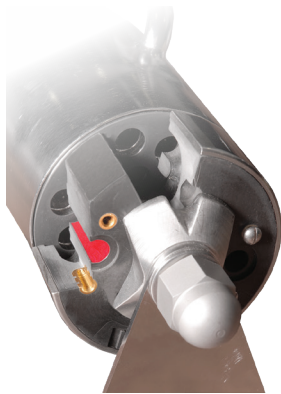

B1 Series

Each Reverse Osmosis module comprises 18 perforated stainless steel tubes in the form of a shell and tube, each tube fitted with a membrane element. Flow of the process fluid through each of the tubes is effected by specially designed end caps connecting all eighteen tubes in series. For viscous materials an alternative end cap arrangement is available which allows the overall pressure drop to be minimised.

The open channel, highly turbulent flow design allows a wide variety of process liquors to be concentrated, with minimal pretreatment. High levels of suspended materials can be tolerated. The design is free of dead spaces, which reduces the fouling potential of the membranes while ensuring maximum effectiveness of cleaning in-situ procedures.

Series Flow Arrangement

For reverse osmosis systems the “series flow” module has channels moulded in the end-caps connecting all the 18 tubes in series.

Module Length (m)	Membrane Area (m)	Weight Empty (kg)	Hold-up Volume Tube-side (Litres)	Hold-up Volume Shroud-side (Litres)	Membrane Tube ID. (mm)
1.22	.88	14.4	2.8	6.7	12.5
2.44	1.75	24.0	5.6	13.3	12.5
3.66	2.63	33.7	8.4	20	12.5

Connection	
Permeate	12.5mm OD for flexible hose
Feed	For 12.5mm oval flange

Tube-Side Mechanical Operating Limits	
Operating Pressure	Up to 64 bar max
Pressure Drop	10 bar max
Operating Temperature	Up to 80°C
Shroud Material	AISI 316 Stainless Steel
Membrane Type	A range of NF & RO membranes

CASE STUDY HISTORY

- Multi-stage Treatment of Landfill Leachate
- Tomato Juice Concentration
- Tubular membrane effluent treatment plant



PCI Membranes

UF, NF & RO Modules - Twin Entry Flow Arrangement

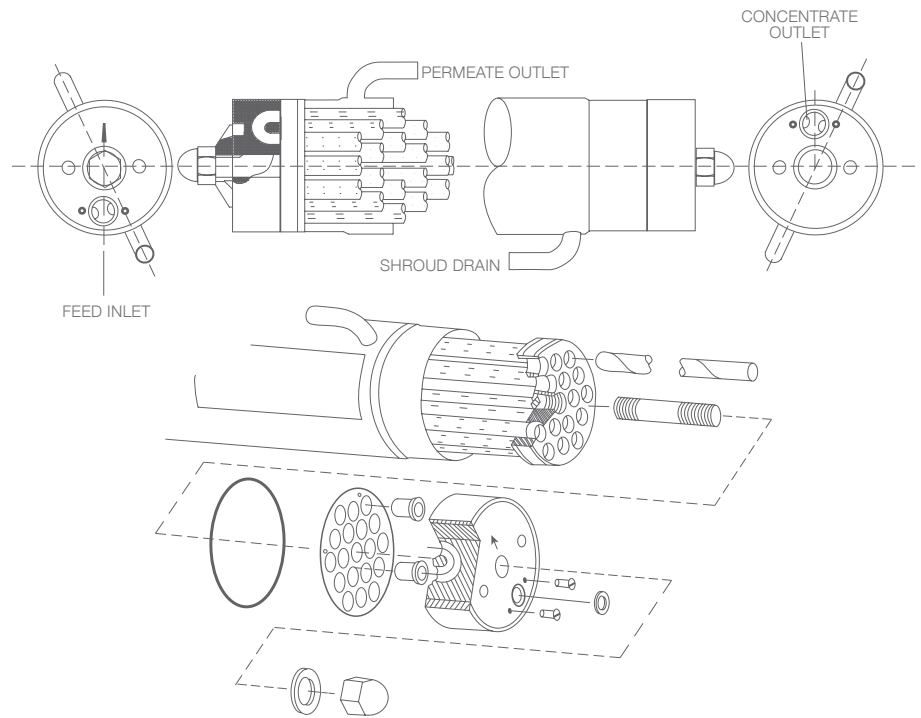
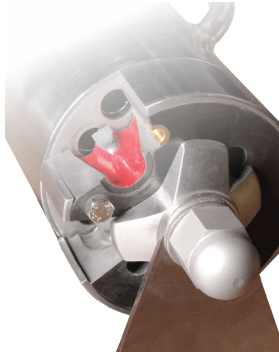

B1 Series

Each ultrafiltration module comprises 18 perforated stainless steel tubes in the form of a shell and tube, each tube fitted with a membrane element. Flow of the process fluid through each of the tubes is effected by specially designed end caps providing 2 parallel channels, each of 9 tubes in series. This allows viscous materials to be processed and high cross flow velocities to be used with acceptable pressure drop.

For non-viscous materials with operation at high pressure (RO conditions) an alternative end cap arrangement is available which results in lower energy consumption.

The open channel, highly turbulent flow design allows a wide variety of process liquors to be concentrated, with minimal pretreatment. High levels of suspended materials can be tolerated. The design is free of dead spaces, which reduces the fouling potential of the membranes while ensuring maximum effectiveness of clean-in-situ procedures.

Twin Entry Flow Arrangement

An end-cap type (known as "twin" or "double-entry") that provides two parallel channels each of nine tubes in series. Allowing viscous materials to be processed and higher crossflow velocities to be used with overall pressure drop minimised.

Module Length (m)	Membrane Area (m ²)	Weight Empty (kg)	Hold-up Volume Tube-side (Litres)	Hold-up Volume Shroud-side (Litres)	Membrane Tube ID. (mm)
2.44	1.75	24.0	5.6	13.3	12.5
3.66	2.63	33.7	8.4	20	12.5

Connection	
Permeate	19mm OF for flexible hose
Feed	For 19mm oval flange

Tube-Side Mechanical Operating Limits	
Operating Pressure	Up to 16 bar max
Pressure Drop	10 bar max
Operating Temperature	Up to 80°C
Shroud Material	AISI 316 Stainless Steel
Membrane Type	A range of UF membranes

CASE STUDY HISTORY

- Multi-stage Treatment of Landfill Leachate
- Tomato Juice Concentration
- Tubular membrane effluent treatment plant



PCI Membranes

Ultrafiltration Modules Parallel Flow Arrangement

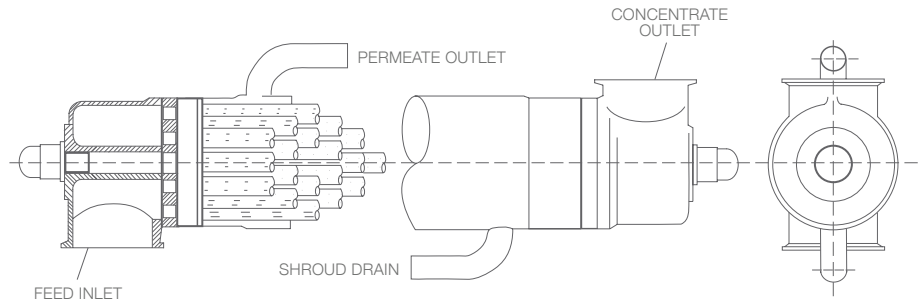

B1 Series

Each module comprises 18 perforated stainless steel tubes in the form of a shell and tube, each tube fitted with a membrane element. Flow of the process fluid through each of the tubes is effected by specially designed end cap providing 18 parallel channels.

This allows viscous materials to be processed and high cross flow velocities to be used with acceptable pressure drop. For less viscous materials an alternative end cap arrangements are available which results in lower energy consumption.

The open channel, highly turbulent flow design allows a wide variety of process liquors to be concentrated, with minimal pretreatment. High levels of suspended materials can be tolerated. The design is free of dead spaces, which reduces the fouling potential of the membranes while ensuring maximum effectiveness of cleaning-in-situ procedures.

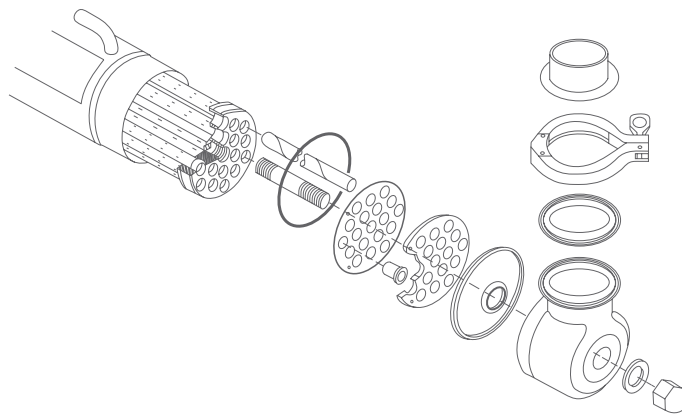

Module Length (m)	Membrane Area (m ²)	Weight Empty (kg)	Hold-up Volume Tube-side (Litres)	Hold-up Volume Shroud-side (Litres)	Membrane Tube ID. (mm)
2.44	1.75	24.2	6.4	13.3	12.5
3.66	2.63	33.8	9.2	20	12.5

Connection	
Permeate	19mm OF for flexible hose
Feed	For 2 1/2" Tri-Clamp

Tube-Side Mechanical Operating Limits	
Operating Pressure	Up to 16 bar max
Pressure Drop	10 bar max
Operating Temperature	Up to 80°C
Shroud Material	AISI 316 Stainless Steel
Membrane Type	A range of UF membranes

Parallel Flow Arrangement

This end-cap allows all 18 tubes to operate in parallel allowing the highest crossflow velocities to be used with acceptable pressure drop.

CASE STUDY HISTORY

- Multi-stage Treatment of Landfill Leachate
- Tomato Juice Concentration
- Tubular membrane effluent treatment plant

